

## Camera / Light Unit

An example of this product can be seen below; however the flexibility and adaptability of the unit means that it can be easily tailored to suit customer requirements. The lightweight, compact unit is portable, and can be fixed to a wide range of deployment platforms. The unit can also be used as a fixed monitoring device. Available as a stand-alone product, or as part of an integrated system, the unit can be supplied with lighting and/or a standard electrical connector upon request. An IP65 variant is also available.

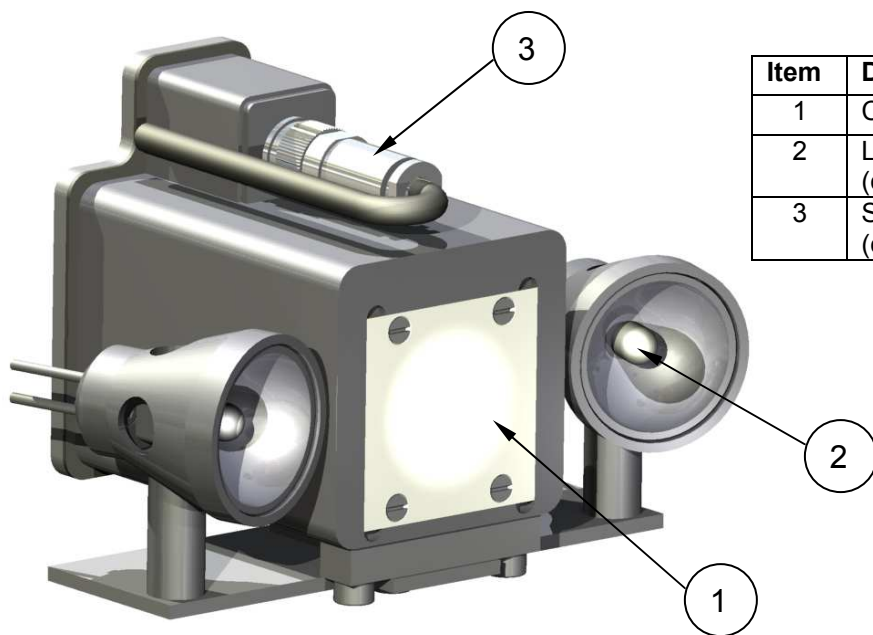

Item	Description
1	CCD Camera
2	Low Voltage Halogen Bulb (optional)
3	Standard Electrical Connector (optional)

*Unit shown with optional lighting and electrical connector*

Example Specification			
<b>Camera Module</b>		<b>Imaging</b>	<b>Lighting (optional)</b>
Dimensions	~ 90 x 60 x 90mm	Colour	Bulb Life 3000 Hours
Weight	~ 1.2kg	10x Optical Zoom	Voltage 12 V
Body Material	Stainless Steel	4x Digital Zoom	Wattage 35 W
Rad. Tolerance	20,000Gy	Auto/Manual Focus	
Video Output	VBS: 1.0 Vp-p (Sync Negative) and Y/C	Auto/Manual Iris	
		Auto/Manual Light Balance	

Tel No. +44 (0)1653 602847  
 Fax No. +44 (0)1653 697379  
 Email: products@jfnl.co.uk

