

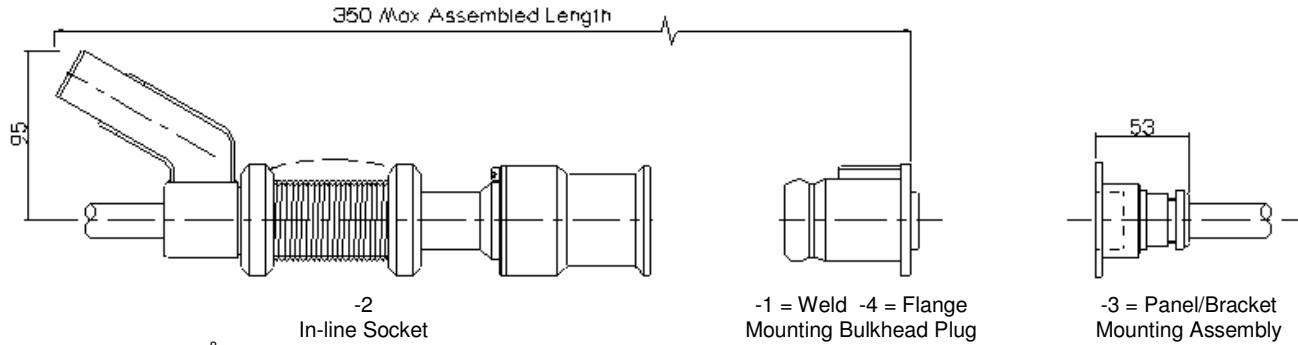

Radiation Tolerant Compliant Connectors Data Sheet



Radiation tolerant to 10^8 Rads
 Stainless steel housing
 Waterproof to IP 66
 Keyed to prevent incorrect connections
 Alternate insert types may be incorporated
 Part of a range of products designed for use by large power manipulators and MSMs
 Adopted by Sellafield Ltd as an Intermediate Level Waste (ILW) Standard Product

Ordering Code

Secondary Key Position if Required

129/12/xxx - 1 A S - (K1 to K13) - M25 ————— Gland Thread Size

Type and Size of Coupler Connector
 003 = Size 20, 010 = Size 22

S = Socket Contacts: P = Pin Contacts

- 1 = Weld Mounting Bulkhead Plug
- 2 = In-line Compliant Socket
- 3 = Panel/Bracket Mounting Assembly
- 4 = Flang Mounting Bulkhead Plug

Contact Code

Operating Voltage: 700 VDC/500 AC Vrms

Test Voltage: 2000 AC Vrms

Inset Type	No. Of Ways	Contacts	Contact Code
22 - 14	19	19 x 16 awg	C
22 - 19	14	14 x 16 awg	B
22 - 22	4	4 x 8 awg	A
20 - 29	17	17 x 16 awg	F
20 - 27	14	14 x 16 awg	E
20 - 33	11	11 x 16 awg	D
20 - 16	9	7 x 16 awg	C
		2 x 12 awg	
20 - 17	6	1 x 16 awg	B
		5 x 12 awg	
20 - 4	4	4 x 12 awg	A

Contact Size	Max Current (at 20°C)	Available Crimp Bucket Sizes (Standard Underlined)
16	22 Amps	16 - 12, <u>16 - 16</u> , 16 - 20
12	41 Amps	<u>12 - 12</u> , 12 - 16
8	74 Amps	<u>8 - 8</u>



Ennerdale Mill Business Park, Egremont, Cumbria, CA22 2NL
 Tel (0) 1946 823502 Fax (0) 1946 821065

A subsidiary of James Fisher and Sons Public Limited Company
 Registered Number 5165202 Vat Registration Number 154552370

Registered Office Fisher House Michaelson Road Barrow-in-Furness Cumbria LA14 1HR